



New Generation

CHM 50Hz

Light horizontal multistage centrifugal pump



Stock code:300145



Nanfang Pump Industry Co., Ltd.
CNP Headquarter
Address: Renhe Town, Hangzhou, China
Post code: 311107
Tel:+86-571-86397837,86397810
Fax:+86-571-86397809
E-mail:info@nanfang-pump.com
www.cnppump.com

E210301
subject to amendments



Pumping Water Pumping Honor



Company profile

Nanfang Pump Industry Co.,Ltd (CNP),as a subsidiary of Nanfang Zhongjin Environment Co.,Ltd, was founded in 1991,and listed on Shenzhen Stock Exchange on December 9,2010 with stock code 300145.

In 2019, CNP's annual output exceeded 900,000 units/set with nearly 3 billion sales revenue, continuing to maintain high growth. As a national enterprise technology center, CNP has flagship ultra-high efficient product -new generation CDM (F) light vertical multistage centrifugal pump, MEI≥ 0.7. Same series high temperature pump products are developed in 2019 to satisfy high temperature applications. All light stainless steel pump product series grow stably. Advanced frequency conversion water supply equipment has been innovated to the 6th generation. Fire pump and diesel engine have obtained UL certification. TD in-line pump, NIS/NISO end suction pump, NSC split casing pump, WQ sewage pump, PQ stainless steel fountain submersible pump, BP silent tube pump, pool pump, non-blocking self-priming sewage pump, metering pump, oil pump and other pump products, can meet various application needs of different fields.

CNP has a complete sales network both in domestic and overseas market,exporting to over 60 countries and regions, maintaining long-g relationship with our clients. CNP pumps have been widely applied in various fields like water treatment, water supply and drainage, HVAC, industrial application, seawater desalination, energy and power etc.

CNP, a green water expert beside you.

Content

Performance range	1
Performance scope	1
Summary	2
Motor.....	2
Operating condition	2
Model definition	2
Application	2
Curve conditions	2
CHM 1,3,5 Material list	3
CHM 10,15,20 Material list	4
CHM 1 Performance curves、Performance table.....	5
CHM 3 Performance curves、Performance table.....	6
CHM 5 Performance curves、Performance table	7
CHM 10 Performance curves、Performance table.....	8
CHM 15 Performance curves、Performance table.....	9
CHM 20 Performance curves、Performance table.....	10
CHM 1,3,5 Installation sketch.....	11
CHM 10,15,20 Installation sketch	12

Performance range

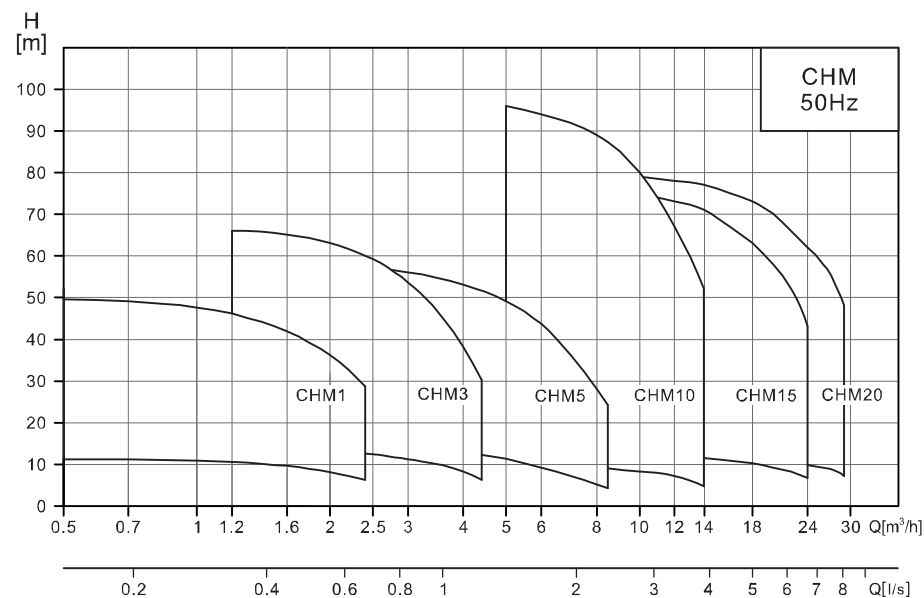

Performance scope

Description	Model	CHM					
		1	3	5	10	15	20
Rated flow [m³/h]		1	3	5	10	15	20
Rated flow [l/s]		0.28	0.83	1.39	2.78	4.17	5.56
Flow range [m³/h]		0.5~2.4	1.2~4.4	2.5~8.5	5~14	8~24	10~29
Flow range [l/s]		0.14~0.67	0.33~1.22	0.69~2.36	1.39~3.89	2.22~6.67	2.78~8.06
Max. pressure [bar]		5	6.6	5.7	9.6	7.6	7.9
Power [kW]		0.37~0.55	0.37~1.1	0.37~1.1	0.75~4	1.1~4.8	1.1~7.5
Temp. [°C]		-15~+105					
Max. efficiency [%]		47	58	68	70	72	72
Pipelines		G1	G1	Input G1½/Output G1	G1½	G2	G2

Summary

CHM is non-self-priming light horizontal multistage centrifugal pump. It has compact structure with extended shaft motor and the liquid is input in axis direction and output in radius direction. The flow passage adopts the process of stainless steel plate stamping and welding, which features the pump of energy efficiency, low noise, environmental protection, beautiful appearance, light weight, convenient installation and maintenance, and high reliability.

Motor

TEFC, 2-pole motor;
 Protection class: Ip55;
 Insulation class: F;
 Standard voltage: 50Hz 1×220V
 3×220V / 380V
 3×380V
 Max. power of single-phase motor is 2.2KW

Operating condition

This pump is applied for thin, clean, non-flammable, non-explosive, solid free, fiber free, physically and chemically water-like liquid.

Liquid temperature:

- 15°C to 70°C for the normal temperature type
- 15°C to 105°C for the hot water type

Ambient temp.: up to 40°C

Max. working pressure: 10 bar

The maximum inlet pressure are limited by the maximum working pressure.

Model definition

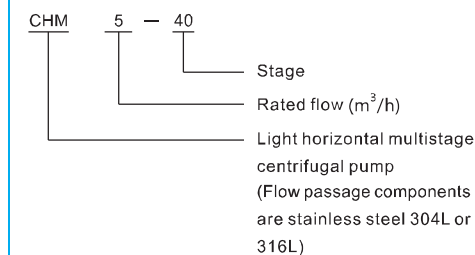

Application

CHM series pump is mainly used in industry:

- Air conditional system
- Cooling system
- Industrial cleaning
- Water treatment (Water purification)
- Aquaculture
- Fertilization/measuring system
- Environment application
- Other specific application

Curve conditions

The requirements applies to all the performance curves below:

1. All curves are based on the measured value of the motor at a constant speed of 2900rpm.
2. Curve tolerance in conformity to S9906:2012, grade 3B.
3. Measurement is done with 20°C air-free water, kinematic viscosity of 1mm²/sec.
4. The pump use should refer to the performance range of the bold curve to prevent overheating by too little flow or motor overload by excessive flow.

CHM1,3,5 Sectional drawing

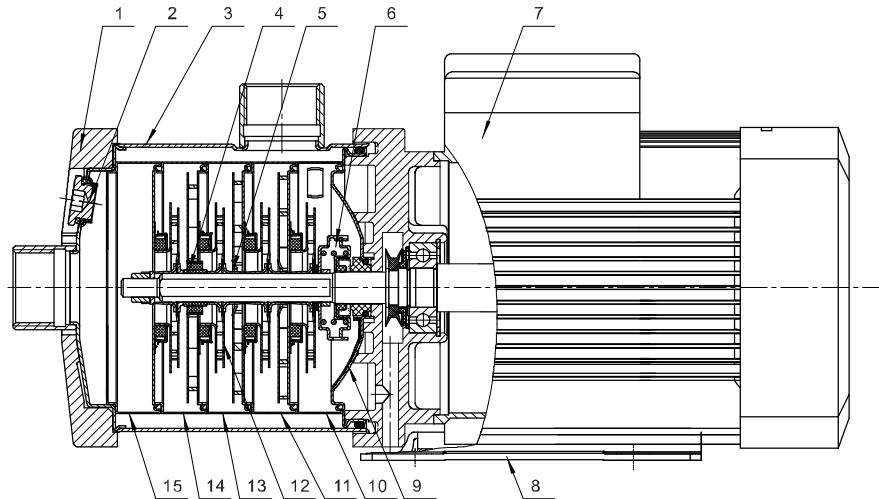

Material list

No.	Name	Material	AISI/ASTM
1	Clamp plate	Die-casting aluminum	ASTM383.1
2	Plug	Stainless steel	AISI304
3	Inlet and outlet chamber	Stainless steel	AISI304
4	Bearing	Tungsten carbide	
5	Impeller sleeve	Stainless steel	AISI304
6	Mechanical seals	Graphite/Silicon carbide	
7	Motor		
8	Base plate	Steel plate	AISI1015
9	Back seat	Stainless steel	AISI304
10	Top diffuser	Stainless steel	AISI304
11	Diffuser	Stainless steel	AISI304
12	Impeller	Stainless steel	AISI304
13	Support diffuser	Stainless steel	AISI304
14	Inducer	Stainless steel	AISI304
15	Inducer cover	Stainless steel	AISI304

Note: Other materials can be customized according to customer requirements.

CHM10,15,20 Sectional drawing

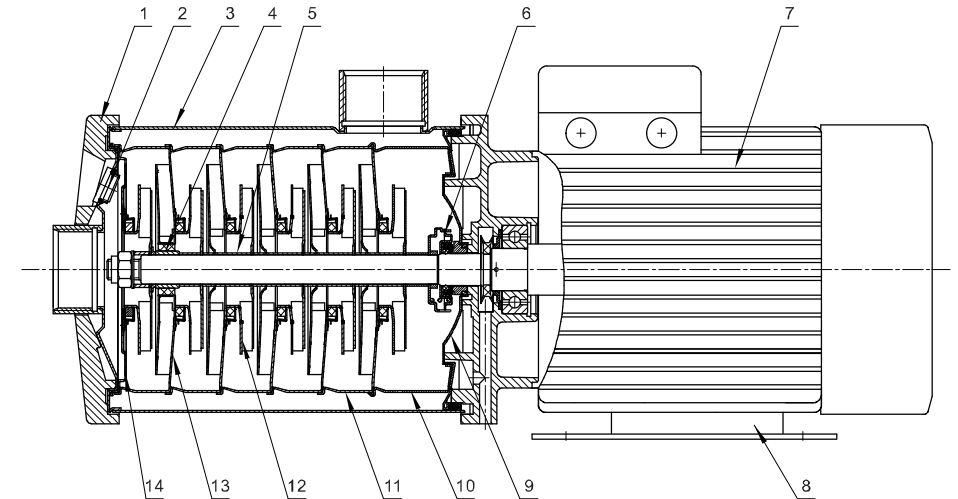

Material list

No.	Name	Material	AISI/ASTM
1	Clamp plate	Die-casting aluminum	ASTM383.1
2	Plug	Stainless steel	AISI304
3	Inlet and outlet chamber	Stainless steel	AISI304
4	Bearing	Tungsten carbide	
5	Impeller sleeve	Stainless steel	AISI304
6	Mechanical seals	Graphite/Silicon carbide	
7	Motor		
8	Base plate	Steel plate	AISI1015
9	Back seat	Stainless steel	AISI304
10	Discharge diffuser	Stainless steel	AISI304
11	Diffuser	Stainless steel	AISI304
12	Impeller	Stainless steel	AISI304
13	Support diffuser	Stainless steel	AISI304
14	Inducer	Stainless steel	AISI304

Note: Other materials can be customized according to customer requirements.

CHM1 Performance curves

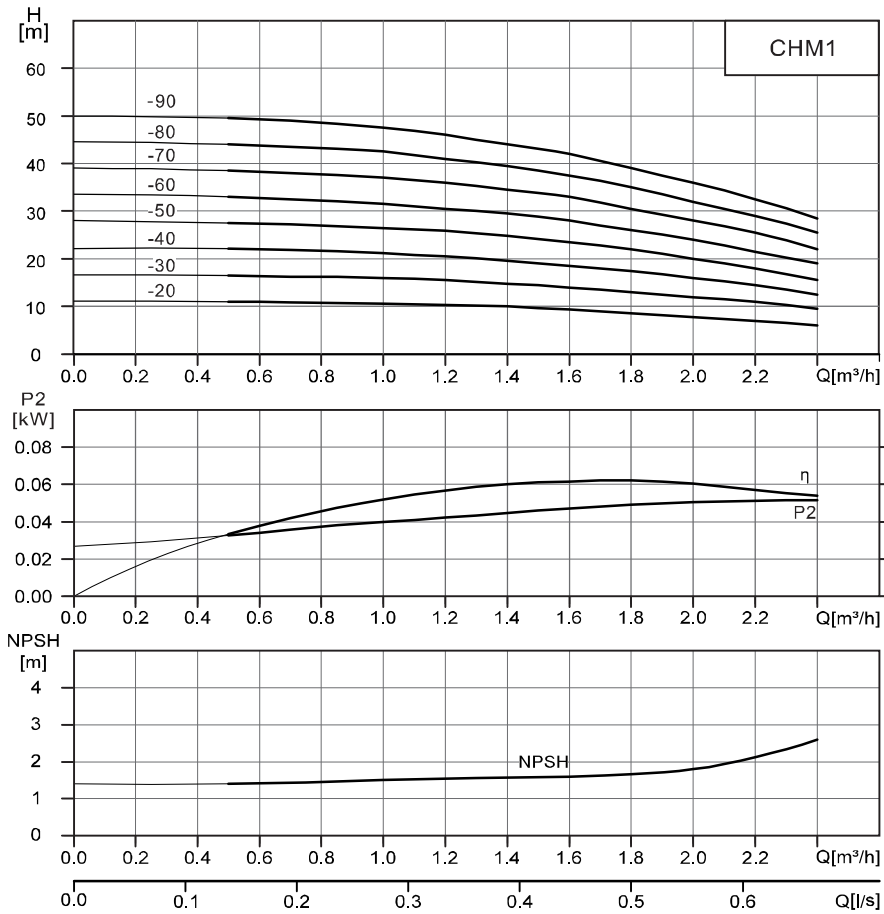

CHM1 Performance table

Model	Motor(kW)	Q(m³/h)	0	0.5	0.7	1	1.2	1.4	1.6	1.8	2	2.2	2.4
1-20	0.37	H(m)	11.1	11	10.9	10.6	10.3	10	9.5	8.7	8	7	6
1-30	0.37		16.6	16.5	16.4	16	15.5	14.8	14	13	12	11	9.5
1-40	0.37		22.2	22	21.9	21.2	20.5	19.6	18.5	17.5	16	14.5	12.5
1-50	0.37		28	27.5	27.2	26.5	25.5	24.5	23.5	22	20	18	15.5
1-60	0.37		33.5	33	32.5	31.5	30.5	29.5	28	26	24	21.5	19
1-70	0.37		39	38.5	38	37	36	34.5	33	30.5	28	25.5	22
1-80	0.55		44.5	44	43.5	42.5	41	39.5	37.5	35	32	29	25.5
1-90	0.55		50	49.5	49	47.5	46	44	42	39	36	32.5	28.5

CHM3 Performance curves

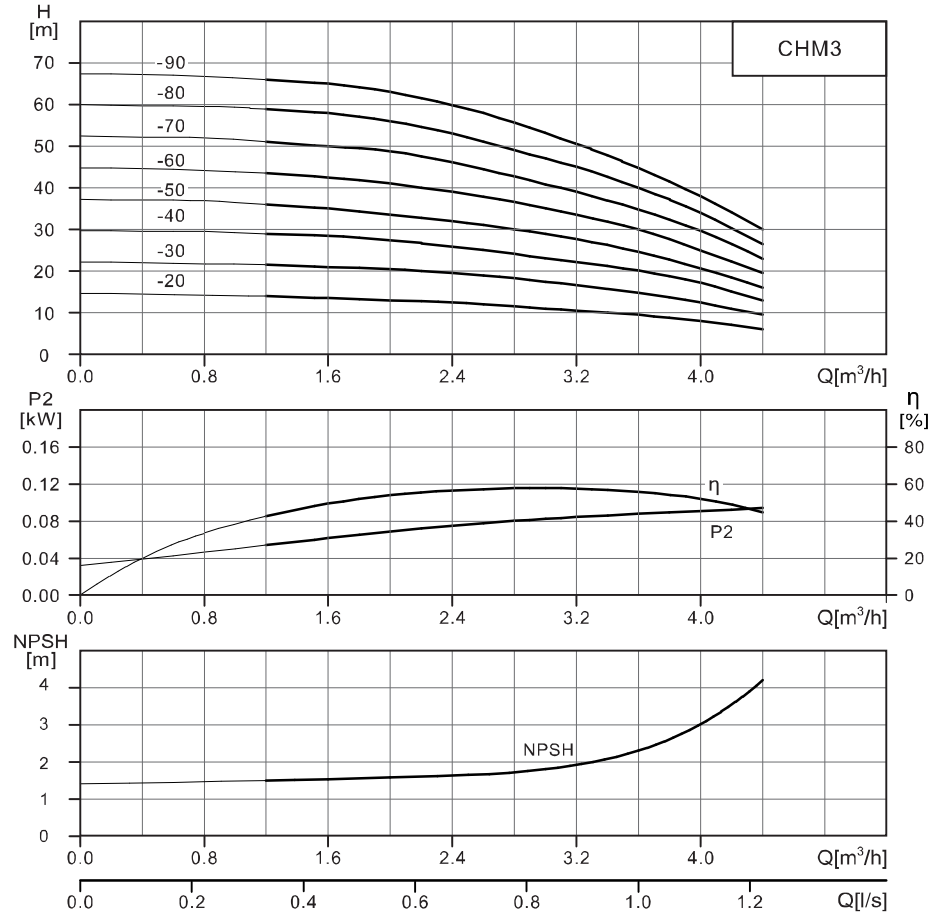

CHM3 Performance table

Model	Motor(kW)	Q(m³/h)	0	1.2	1.6	2	2.4	2.8	3	3.2	3.6	4	4.4
3-20	0.37	H(m)	14.7	14	13.5	13	12.5	11.5	11	10.5	9.5	8	6
3-30	0.37		22.2	21.5	21	20.5	19.5	18	17	16.5	15	12.5	9.5
3-40	0.37		29.7	29	28.5	27.5	26	24	23	22	20	17	13
3-50	0.55		37.2	36	35	33.5	32	30	29	28	25	21	16
3-60	0.55		45	43.5	42.5	41	39	36.5	35	33.5	30	25	19.5
3-70	0.75		52.5	51	50	49	46	43	41	39.5	35	30	23
3-80	0.75		60	58.5	58	56	53	49	47	45	40	34	26.5
3-90	1.1		67.5	66	65	63	60	56	53	51	45	38	30

CHM5 Performance curves

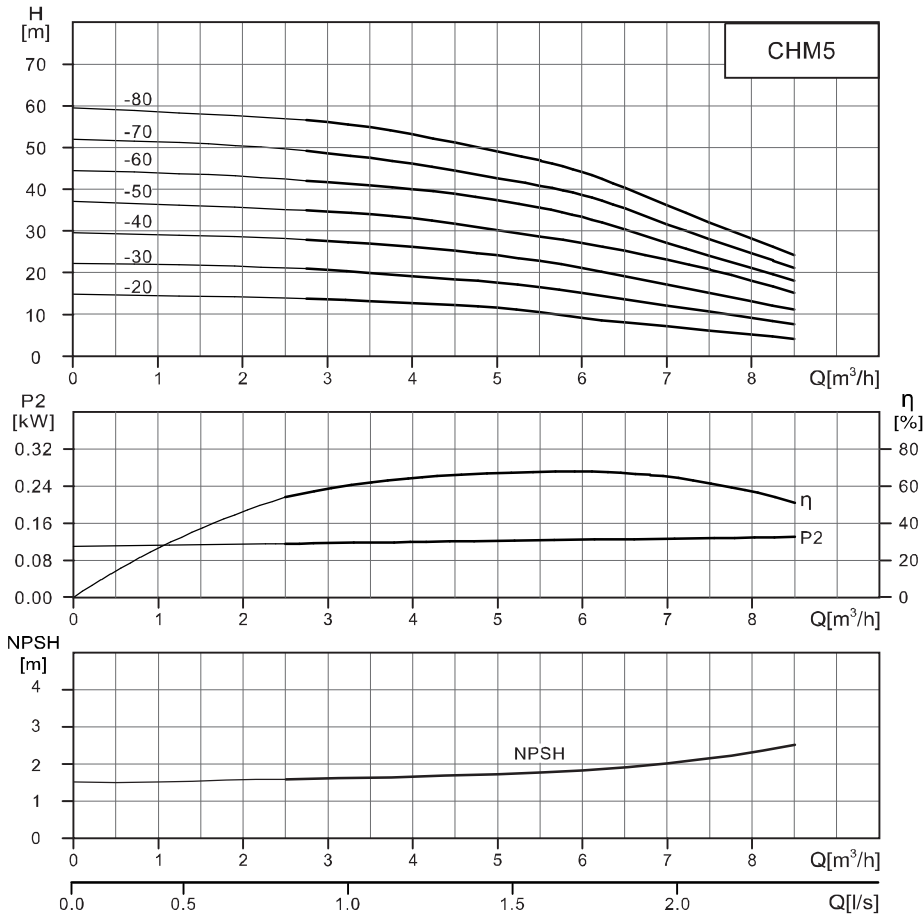

CHM5 Performance table

Model	Motor(kW)	Q(m³/h)	0	2.5	3	4	5	6	7	8	8.5
5-20	0.37	H(m)	14.7	13.5	13.3	12.5	11.5	9	7	5	4
5-30	0.55		22.1	21	20.5	19	17.5	15	12	9	7.5
5-40	0.55		29.5	28	27.5	26	24	21	17	13	11
5-50	0.75		37	35	34.5	33	30	27	23	18	15
5-60	1.1		44.5	42	41.5	40	37	33	27	21	18
5-70	1.1		52	49.5	48.5	46	42.5	38.5	31.5	24.5	21
5-80	1.1		59	57	56	53	49	44	36	28	24

CHM10 Performance curves

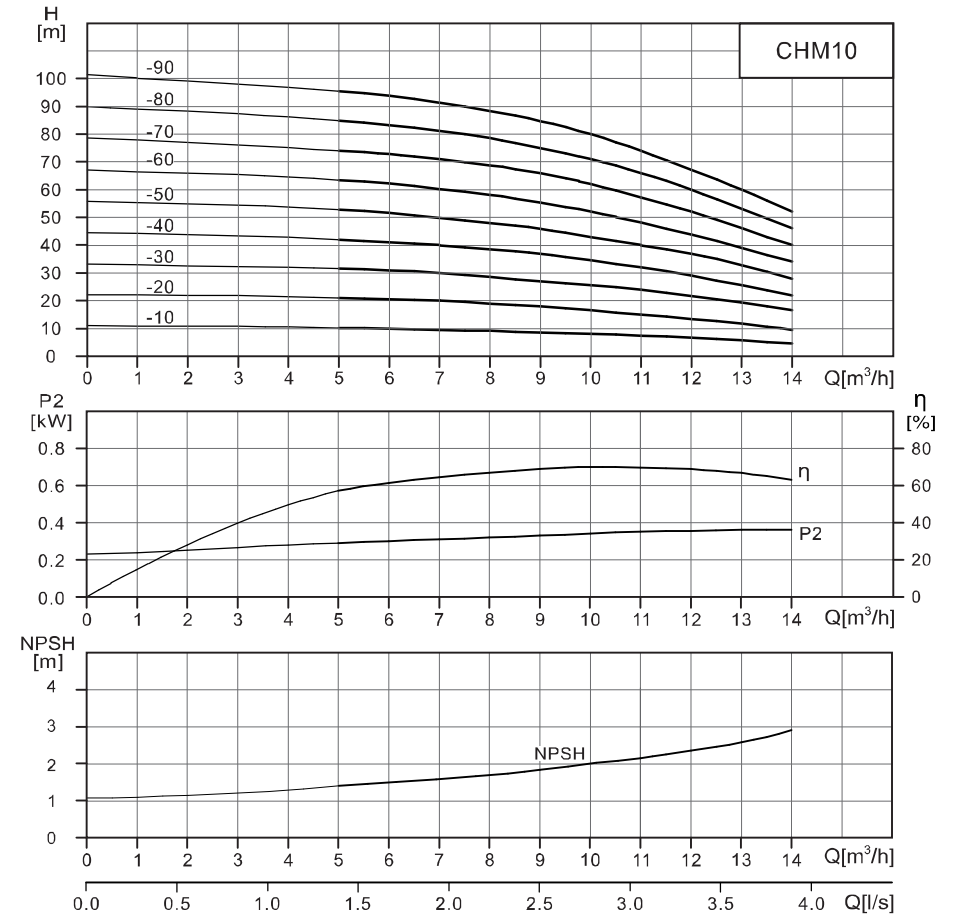

CHM10 Performance table

Model	Motor(kW)	Q(m³/h)	0	5	6	8	10	12	14
10-10	0.75	H(m)	11	10.2	10	9	8	7	4.5
10-20	0.75		22.2	21	20.5	19	16.5	13.5	9.5
10-30	1.1		33.3	31.5	31	28.5	25.5	22	16.5
10-40	1.5		44.5	42	41	38	34	29	22
10-50	2.2		56	52.5	51	48	43	37	28
10-60	2.2		67	63	62	58	52	44	34
10-70	3		78.5	74	73	69	62	52	40
10-80	3		90	85	84	79	71	60	46
10-90	4		101.5	96	94	89	80	67	52

CHM15 Performance curves

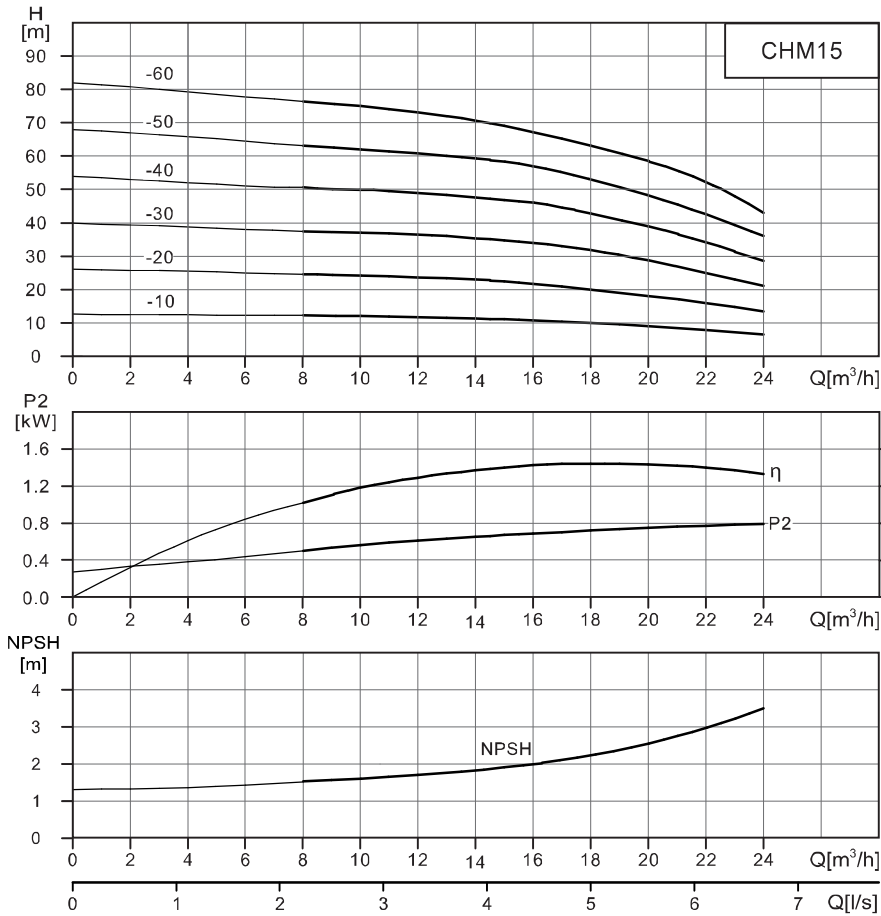

CHM15 Performance table

Model	Motor(kW)	Q(m³/h)	0	8	10	12	14	15	16	18	20	22	24
15-10	1.1	H(m)	12.6	12.2	12	11.8	11.5	11	10.5	10	9	8	6.5
15-20	2.2		26	24.5	24	23.5	23	22.5	21.5	20	18	16	13.5
15-30	3		40	37.5	37	36.5	35.5	34.5	34	32	29	25	21
15-40	4		54	50.5	50	49	47.5	47	46	43	39	34	28.5
15-50	4		68	63	62	61	59	58	57	53	48	42.5	36
15-60	4.8		82	76	75	73	71	69	67	63	58	52	43

CHM20 Performance curves

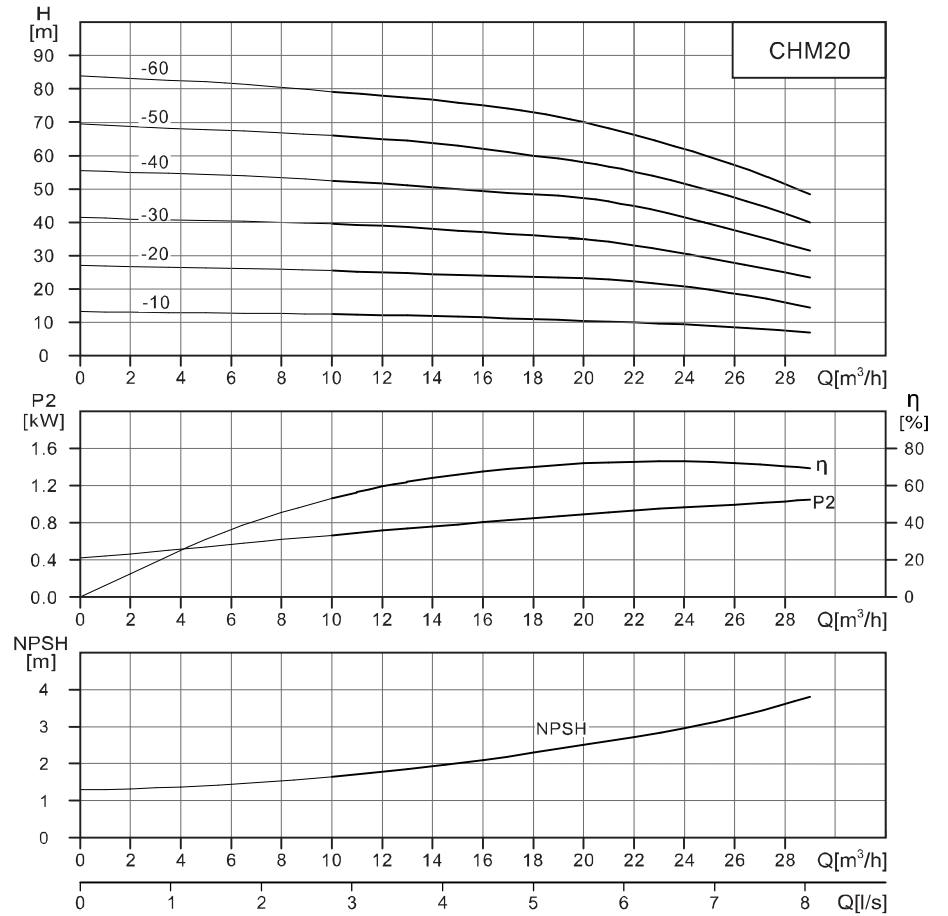

CHM20 Performance table

Model	Motor(kW)	Q(m³/h)	0	10	12	14	16	18	20	22	24	26	28	29
20-10	1.1	H(m)	13.3	12.5	12.3	12	11.5	11	10.5	10	9.5	9	8	7
20-20	2.2		27.2	25.5	25	24.5	24	23.7	23	22	20.5	18	16	14.5
20-30	4		41.5	39.5	39	38	37	36	35	33	31	28	25	23.5
20-40	4.8		55.5	52.5	51	50	49	48.5	47	45	41.5	37	33	31.5
20-50	5.5		69.5	66	65	64	62	60	58	55	51	47	42	40
20-60	7.5		84	79	78	77	75	73	70	66	62	58	52	48

CHM1,3,5 Installation sketch

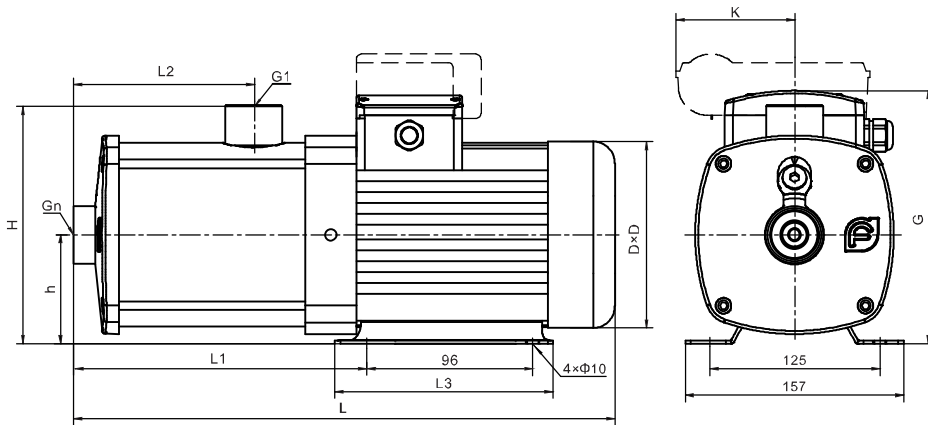

CHM10,15,20 Installation sketch

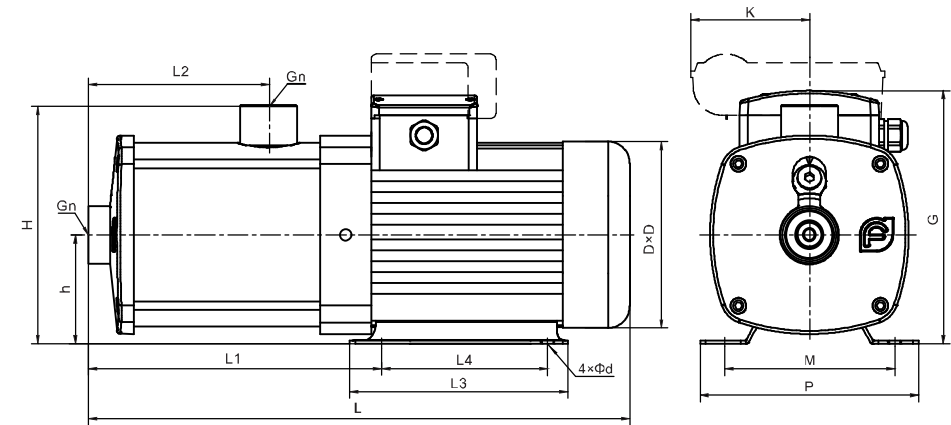

CHM1,3,5 Dimensions and weight

Motor	Model	Dimensions(mm)										Weight (kg)
		L	L1	L2	L3	h	H	G	D	n	K	
Three phase/ Single phase	1-20	328	137	78	150	75	165	178/212	141	1	/62	9
	1-30	328	137	78	150	75	165	178/212	141	1	/62	9
	1-40	348	157	98	150	75	165	178/212	141	1	/62	9
	1-50	368	177	118	150	75	165	178/212	141	1	/62	10
	1-60	388	197	138	150	75	165	178/212	141	1	/62	10
	1-70	408	217	158	150	75	165	178/212	141	1	/62	11
	1-80	428	237	178	150	75	165	178/212	141	1	/62	12
	1-90	448	257	198	150	75	165	178/212	141	1	/62	12
	3-20	328	137	78	150	75	165	178/212	141	1	/62	9
Three phase/ Single phase	3-30	328	137	78	150	75	165	178/212	141	1	/62	9
	3-40	348	157	98	150	75	165	178/212	141	1	/62	9
	3-50	368	177	118	150	75	165	178/212	141	1	/62	11
	3-60	388	197	138	150	75	165	178/212	141	1	/62	11
	3-70	429/431	217	158	160	85	175	178/212	151/161	1	/91	14
Three phase/ Single phase	3-80	449/451	237	178	160	85	175	178/212	151/161	1	/91	15
	3-90	469/491	257	198	160	85	175	178/212	151/161	1	/91	16
	5-20	322	131	72	150	75	165	178/212	141	1¼	/62	9
	5-30	376	185	126	150	75	165	178/212	141	1¼	/62	10
	5-40	376	185	126	150	75	165	178/212	141	1¼	/62	11
	5-50	424/426	212	153	160	85	175	178/230	151/161	1¼	/91	14
	5-60	451/473	239	180	160	85	175	178/230	151/161	1¼	/91	15
	5-70	478/500	266	207	160	85	175	178/230	151/161	1¼	/91	16
5-80	505/527	293	234	160	85	175	178/230	151/161	1¼	/91	16	

CHM10,15,20 Dimensions and weight

Motor	Model	Dimensions(mm)														Weight (kg)
		L	L1	L2	L3	L4	h	H	n	d	D	G	M	P	K	
Three phase/ Single phase	10-10	366/368	172/190	78	140	96	100	218	1½	10	151/161	210/246	125	158	/91	14
	10-20	366/368	172/190	78	140	96	100	218	1½	10	151/161	210/246	125	158	/91	14
	10-30	396/418	202/222	108	140	96	100	218	1½	10	151/161	210/246	125	158	/91	18
	10-40	467/479	249/269	138	200	140	100	218	1½	10	171/175	220/256	160	200	/91	23
	10-50	497/509	279/299	168	200	140	100	218	1½	10	171/175	220/256	160	200	/91	24
	10-60	527/539	309/329	198	200	140	100	218	1½	10	171/175	220/256	160	200	/91	24
	10-70	608/	338/	228	180	140	100	218	1½	10	196/	232/	160	200	/	31
	10-80	638/	368/	258	180	140	100	218	1½	10	196/	232/	160	200	/	31
	10-90	679/	417/	288	180	140	112	230	1½	12	214/	262/	190	230	/	37
	Three phase/ Single phase	15-10	379/401	187/207	93	140	96	100	218	2	10	151/161	210/246	125	158	/91
15-20		420/432	203/200	93	200	140	100	218	2	10	171/175	220/256	160	200	/91	22
15-30		516/	247/	138	180	140	100	218	2	10	196/	232/	160	200	/	30
15-40		572/	311/	183	180	140	112	230	2	12	214/	262/	190	230	/	37
15-50		617/	356/	228	180	140	112	230	2	12	214/	262/	190	230	/	37
15-60		662/	401/	273	180	140	112	230	2	12	214/	262/	190	230	/	42
20-10		379/401	187/207	93	140	96	100	218	2	10	151/161	210/246	125	158	/91	14
20-20		420/432	203/200	93	200	140	100	218	2	10	171/175	220/256	160	200	/91	22
Three phase/ Single phase	20-30	527/	266/	138	180	140	112	230	2	12	214/	262/	190	230	/	36
	20-40	572/	311/	183	180	140	112	230	2	12	214/	262/	190	230	/	39
	20-50	663/	370/	228	184	140	132	250	2	12	257/	300/	216	248	/	50
	20-60	708/	415/	273	184	140	132	250	2	12	257/	300/	216	248	/	55